

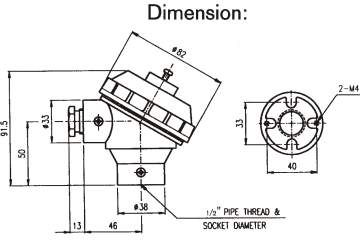
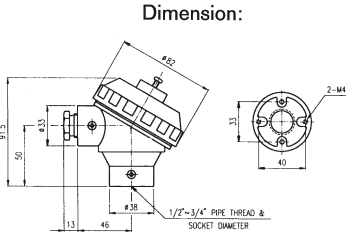
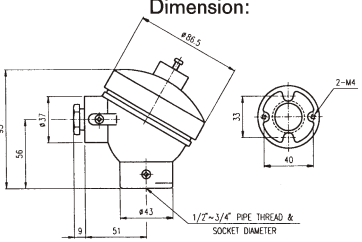
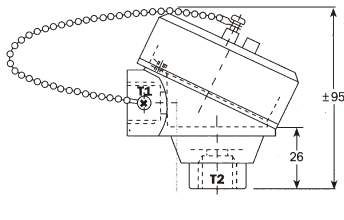
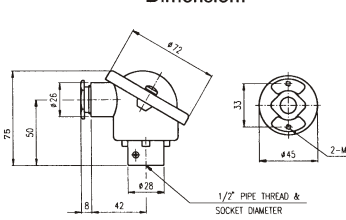
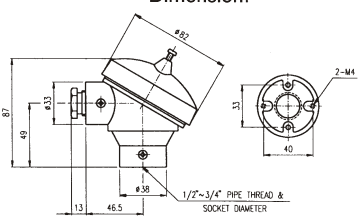
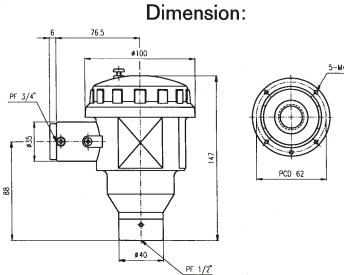
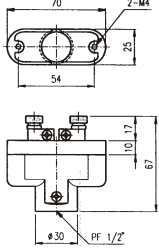
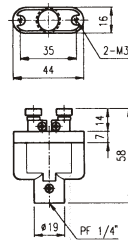
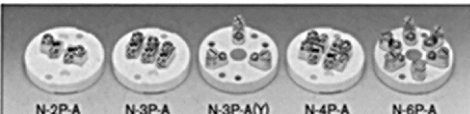
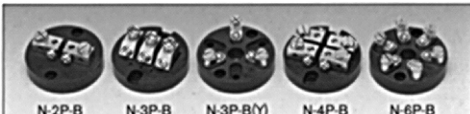

TERMINAL HEAD (接線盒)

UNIT : mm

<p>TYPE : KB</p> <p>MATERIAL 材質: BAKELITE 電木 CLASS 等級 : IP65</p> 	<p>TYPE : KNC</p> <p>MATERIAL 材質: ALUMINUM ALLOY 鋁合金 CLASS 等級 : IP65</p> 	<p>TYPE : KI</p> <p>MATERIAL 材質 : CAST IRON 鑄鐵 CLASS 等級 : 7</p> 
<p>TYPE : 1080AE, 1080SE</p> <p>MATERIAL: 1080AE ALUMINUM ALLOY 鋁合金 1080SE SUS 316 不鏽鋼 316 CLASS 等級 : EXPLOSION PROOF 防爆</p> 	<p>TYPE: KD</p> <p>MATERIAL 材質: ALUMINUM ALLOY 鋁合金 CLASS : IP65</p> 	<p>TYPE: LS</p> <p>MATERIAL 材質: SUS 316 不鏽鋼 316</p> 
<p>TYPE :</p> <p>MATERIAL: ALUMINUM ALLOY 鋁合金 CLASS 等級 : EXPLOSION PROOF 防爆</p> 	<p>TYPE: TL (STD)</p> <p>MATERIAL 材質: ALUMINUM ALLOY 鋁合金 TERMINAL BLOCK 端子座 : CERAMIC OR BAKELITE 陶瓷或電木</p> 	<p>TYPE: TS (MINI)</p> <p>MATERIAL 材質: ALUMINUM ALLOY 鋁合金 TERMINAL BLOCK 端子座 : CERAMIC OR BAKELITE 陶瓷或電木</p> 

TERMINAL BLOCK (端子盤)

<p>TYPE : N-2P-A, N-3P-A, N-3P-A(Y), N-4P-A, N-6P-A MATERIAL 材質: CERAMIC Al₂O₃ 92% 陶瓷</p>  <p>N-2P-A N-3P-A N-3P-A(Y) N-4P-A N-6P-A</p> <p>Terminal Blocks for Connection Heads Material: Ceramic Al₂O₃ 92% Terminal Block Weight: 2P-A(72g), 3P-A(78g), 3P-A(Y)(72g) 4P-A(84g), 6P-A(94g)</p>	<p>TYPE : N-2P-B, N-3P-B, N-3P-B(Y), N-4P-B, N-6P-B MATERIAL 材質: BAKELITE 電木</p>  <p>N-2P-B N-3P-B N-3P-B(Y) N-4P-B N-6P-B</p> <p>Terminal Blocks for Connection Heads Material: Bakelite Terminal Block Weight: 2P-B(56g), 3P-B(68g), 3P-B(Y)(44g) 4P-B(84g), 6P-B(66g)</p>
<p>TYPE : D-2P-A, D-3P-A, D-4P-A, D-6P-A MATERIAL 材質: CERAMIC Al₂O₃ 92% 陶瓷</p>  <p>D-2P-A D-3P-A D-4P-A D-6P-A</p> <p>Terminal Blocks for Connection Heads Material: Ceramic Al₂O₃ 92% Terminal Block Weight: 2P-A(66g), 3P-A(72g) 4P-A(78g), 6P-A(88g)</p>	<p>TYPE : M-2P-C, M-3P-C, M-4P-C, M-6P-C MATERIAL 材質: CERAMIC Al₂O₃ 陶瓷</p>  <p>M-2P-C M-3P-C M-4P-C M-6P-C</p> <p>Terminal Blocks for Connection Heads Material: Ceramic Terminal Block Weight: 2P-C(34g), 3P-C(38g) 4P-C(42g), 6P-C(54g)</p>

STANDARD and MINIATURE plugs , jacks , mounting 標準及迷你型快速接頭

Thermocouple connector 熱電偶快速接頭 FOR TYPE J, K, E, T, R, S)

STANDARD 標準型			MINI 迷你型	
TYPE: TCS M(PLUG)公	TYPE: TCS F(JACK)母		TYPE: TCM M(PLUG)公	TYPE: TCM F(JACK)母
mounting hardware			mounting hardware	
180 °C	260 °C	420 °C	180 °C	180 °C
FIG 6,9,10	FIG 6,7,9	FIG 7,9	FIG 9,10, 11	FIG 8,9

ORDER 訂購方式 : 1. THERMOCOUPLE TYPE 熱電偶種類 2.PLUG OR JACK TYPE 公 或 母
3. HARDWARE TYPE 線夾固定方式

ORDERING EXAMPLE 舉例:

RTD connector 熱電阻快速接頭

STANDARD 標準型		MINI 迷你型	
TYPE: PTS M(PLUG)公	TYPE: PTS F(JACK)母	TYPE: PTM M(PLUG)公	TYPE: PTM F(JACK)母
mounting hardware		mounting hardware	
180 °C		180 °C	
FIG 6,7,9		FIG 6,9,10,11	

ORDER 訂購方式 : 1. RTD TYPE 熱電阻種類 2.PLUG OR JACK TYPE 公 或 母
3. HARDWARE TYPE 線夾固定方式

ORDERING EXAMPLE 舉例:

MOUNTING HARDWARE 線固定夾

MOUNTING HARDWARE 線固定夾				
TYPE: FIG 6	TYPE: FIG 7	TYPE: FIG 8,9	TYPE: FIG 10	TYPE: FIG 11
TYPE: Nipple-union-Nipple				

熱電偶、熱電阻用配件 ASSEMBLIES FOR TC AND RTD

卡套螺栓 Bush Screw-In / Compression fitting

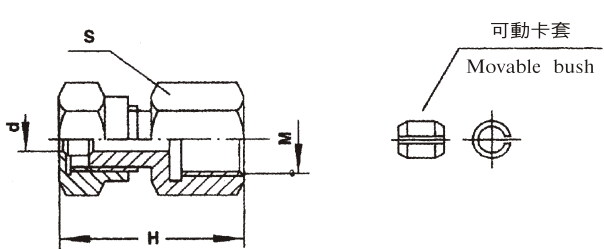
	d 基本參數 Basic parameter	φ 2	φ 3	φ 4	φ 5	φ 6	φ 8
	M	M1.2 x 1.5		M16 x 1.5			
	S	19		22			
	H	≈ 42		≈ 42			
	公稱壓力 Normal Pressure	固定卡套 Fixed bush	2.5MPa				
	可動卡套 Movable bush	常 壓 Atmospheric Pressure					

可動卡套活接頭 Movable Bush Screw-In With Disconnected Joint
Compression fitting with bushing

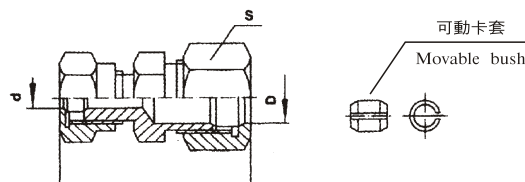
	S	D	d	H
	22	φ 12	φ 3	≈ 50
		φ 16	φ 4	
	30	φ 20	φ 5	
	33	φ 22	φ 6	
φ 8				

防震阻漏彈性螺栓 Spring Screw-In With Vibration Resistant And Leak-Proof
Compression fitting with bayonet cad and spring

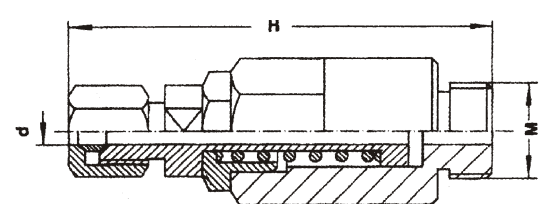
	d	M	H
	φ 3	M16 x 1.5	≈ 81
	φ 4	M18 x 1.5	
	φ 5	M20 x 1.5	
	φ 6	G 1/2"	
	φ 8	G 3/4"	

防震彈性活接頭 Spring Movable Connection With Vibration Resistant
Compression fitting with bayonet cad and spring

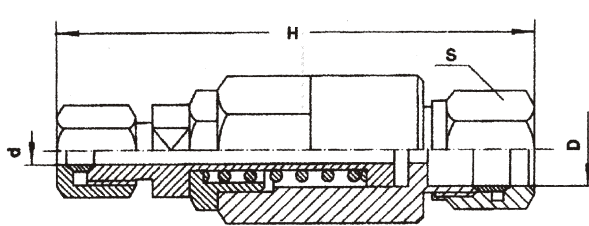
	D	d	S	H
	φ 12	φ 2	24	≈ 90
		φ 3		
	φ 16	φ 4	30	
		φ 5		
	φ 20	φ 6	33	
φ 22	φ 8			

內螺紋卡套轉換接頭 Inner Thread Transmission Connector With Bush Screw-In

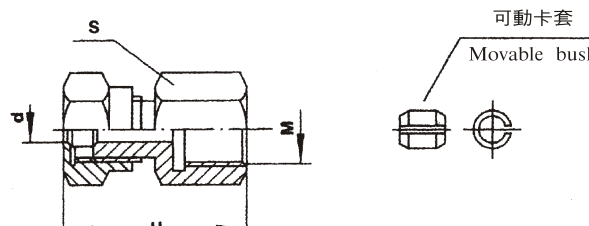
	M	S	d	H
	M12 x 1	24	φ 3	≈ 38
	M16 x 1		φ 4	
	M22 x 1	27	φ 5	
	G 1/2"	25	φ 6	
	G 3/4"	36	φ 8	
	G 1"	40		

汽缸長卡套螺栓 Long Bush Screw-In For Steam Turbine Cylinder

	d	M	S	公稱壓力 Normal pressure
	φ 3	M16 x 1.5	22	2.5MPa
	φ 4			
	φ 5			
	φ 6			

直形保護管固定螺栓 Fixed Screw-In with Straight Protection Tube \ Fixed type bushing

	d	M	h	S	D ₀	公稱壓力 Normal pressure
	φ 10	M24 x 2 G 3/4"	32	32	φ 40	10MPa
	φ 12					
	φ 16	M33 x 2 G 1 1/2"	35	36	φ 48	
	φ 20					

錐形保護管固定螺栓 Fixed Screw-In with Tapered Drilled Thermowell \ Fixed type bushing

	M	h	S	D ₀	公稱壓力 Normal pressure
	M33 x 2	33	36	φ 48	30MPa
	G1				
	1-11.5NPT				

卡套法蘭 Bush Flange

	d	φ 2	φ 3	φ 4	φ 5	φ 6	φ 8
	基本參數 Basic parameter						
	D	φ 50		φ 60			
	D ₀	φ 36		φ 42			
	D ₁	φ 20		φ 42			
	d ₀	φ 7		φ 9			
	S	19		22			
	固定卡套公稱壓力 Fixed bush Normal Pressure	2.5MPa					
	可動卡套公稱壓力 Movable bush Normal Pressure	常 壓 Atmospheric Pressure					

固定法蘭(RF) Fixed Flange(RF)

	d	D	D ₁	d ₁	H	D ₀	公稱壓力 Normal pressure
	φ 8	φ 95	φ 65	φ 45	16	φ 40	2.5MPa
	φ 10						
	φ 12	φ 105	φ 75	φ 50	18		
	φ 16						
	φ 20	φ 115	φ 85	φ 65			
φ 22							
φ 25							

作用中法蘭 Movable Flange

	d	D	D ₁	D ₀	公稱壓力 Normal pressure
	φ 10	φ 70	φ 54	φ 6	常 壓 Atmospheric Pressure
	φ 12				
	φ 16				
	φ 20				
	φ 22				
	φ 25				